

**Citation:** Adibinia, E., Nayebzadeh, S., & Hataminasab, S. H. (2025). Structural Analysis of Factors and Strategies for Addressing Dark Tourism in Iran. *Digital Transformation and Administration Innovation*, 3(4), 1-15.

Received date: 2025-05-29

Revised date: 2025-09-01

Accepted date: 2025-09-06

Published date: 2025-10-01



# Structural Analysis of Factors and Strategies for Addressing Dark Tourism in Iran

Elham Adibinia<sup>1</sup>, Shahnaz Nayebzadeh<sup>2\*</sup>, Seyyed Hassan Hataminasab<sup>2</sup>

1. Ph.D. student, Institute of Market and Business, Y. C., Islamic Azad University, Yazd, Iran

2. Institute of Market and Business, Y. C., Islamic Azad University, Yazd, Iran

\*Correspondence: Snayebzadeh@iau.ac.ir

## Abstract

This study was conducted with the aim of stratifying and analyzing the relationships among the influencing factors and strategies for addressing the negative aspects of dark tourism in Iran, using a quantitative approach and the Interpretive Structural Modeling (ISM) method. The statistical population consisted of experts and specialists in the field of dark tourism, selected through purposive sampling. Data were collected using a closed-ended questionnaire and pairwise comparison of factors. The KMO index in all sections was higher than 0.6, and the Bartlett's test was significant, confirming sampling adequacy and the suitability of data for exploratory factor analysis. The results indicated that among the influencing factors of dark tourism, "psychological characteristics of tourists," "personality traits of tourists," and "government cultural measures" were the most influential and fundamental factors, while "limited attractiveness of dark tourism," "low public awareness," and "existence of development potentials" were identified as the least influential factors. Furthermore, in terms of coping strategies, "prohibition of entry into dangerous war zones" was identified as the most fundamental and influential strategy, while "focusing on historical and educational aspects" was the most affected strategy. The stratified model presented in this research, while identifying direct and indirect relationships among factors, provides a practical framework for policymakers and tourism managers to reduce the negative consequences of this type of tourism and to create the conditions for its sustainable and responsible development by focusing on key factors and implementing prioritized strategies.

**Keywords:** Tourism, Dark Tourism, Interpretive Structural Modeling, Exploratory Factor Analysis, Iran.

## 1. Introduction

Tourism has long been recognized as a multifaceted phenomenon that goes beyond leisure, recreation, and cultural enrichment. Within its diverse forms, dark tourism—defined as travel to sites associated with death, tragedy, and suffering—has emerged as one of the most contested and increasingly popular branches of tourism studies. Over the last three decades, dark tourism has become a critical field of inquiry within tourism research, heritage studies, sociology, and cultural geography. The growth of this field reflects not only the rising demand for visiting sites of trauma and conflict but also broader questions about cultural memory, commodification of tragedy, and the psychological motivations that drive visitors toward such destinations (Hartmann, 2014).

At its core, dark tourism is closely tied to the preservation and reinterpretation of cultural and historical memory. Scholars have noted that engaging with sites of suffering and catastrophe allows societies to acknowledge past traumas and construct



shared narratives for collective remembrance (Bugrova, 2024). These sites often operate as cultural signifiers, bridging the gap between history and contemporary identity. They embody a paradox, functioning both as spaces of mourning and as commodified attractions, raising important ethical questions for policymakers and tourism managers (Korstanje & George, 2015). As a result, the study of dark tourism is not simply about the consumption of morbid experiences but about the complex interplay between heritage, memory, emotion, and market forces (Light, 2017).

The expansion of dark tourism has led to substantial conceptual and empirical debates. One stream of literature has emphasized motivations and visitor experiences, particularly how emotions and cognitive appraisals interact when individuals confront spaces of death and suffering. For example, studies have shown that residents and visitors experience a range of emotions—such as grief, anger, or pride—when encountering dark sites, and these emotions strongly influence their coping mechanisms and behavioral outcomes (Jordan & Prayag, 2022). Similarly, research on the motivational dynamics of young tourists in Southeast Asia suggests that personal curiosity, educational aspirations, and emotional engagement are among the leading drivers for participation in dark tourism (Khalid et al., 2023). The visitor experience, therefore, is deeply embedded in psychological processes that mediate between past trauma and present interpretation (Yan et al., 2016).

Empirical evidence from diverse geographic contexts reinforces the idea that dark tourism is a global phenomenon with locally specific dimensions. In the aftermath of seismic disasters in Nepal, memorial sites such as Barpak and Langtang have become focal points for remembrance and education. These locations are framed as spaces of resilience, offering both locals and foreigners an opportunity to engage with history while supporting community recovery (Kunwar et al., 2019). Similarly, in Serbia, memorial parks like Kragujevački Oktobar have been investigated as emblematic dark tourism sites that reflect national struggles and the collective processing of traumatic histories (Miletić et al., 2023). These examples underline how the meaning and function of dark tourism vary across cultural and political contexts while remaining bound by universal themes of memory, loss, and identity.

A critical development in dark tourism scholarship has been the recognition of its academic and professional significance as a discipline. Scholars argue that the growth of dark tourism studies has transformed the field into a distinctive academic brand, with its own theoretical frameworks, methodological approaches, and professional applications (Nhlabathi & Maharaj, 2020). The trajectory of this field shows how research on death and tragedy has shifted from marginal curiosity to a mainstream topic of inquiry within tourism studies, albeit one that continues to wrestle with ethical and interpretive dilemmas (Assylkhanova et al., 2024).

From a psychological perspective, researchers have explored the emotional and bodily experiences of tourists at dark sites. One influential contribution emphasizes the embodied dimension of dark tourism, where visitors' sensory and affective responses—such as fear, anxiety, or awe—shape their overall experience (Sun & Lv, 2020). This line of inquiry has been expanded to include how the staging and design of dark attractions mediate these responses. Interpretation strategies such as “edutainment,” which blend education with entertainment, have been shown to influence how visitors engage with sites of death in ways that balance learning with emotional impact (Wyatt et al., 2020).

The heritage dimension of dark tourism remains particularly important. Many studies highlight the dissonance that emerges when tragic histories are commodified for tourism purposes. While heritage managers often seek to memorialize the past respectfully, economic pressures can result in the commercialization of suffering (Hartmann, 2014). This dissonance is not uniform but varies across sites and cultural settings, with some emphasizing solemn commemoration and others leaning toward spectacle (Light, 2017). The management of this tension has become a central challenge for heritage and tourism professionals worldwide.

In Asia, several case studies provide insights into the operationalization of violence and tragedy at dark sites. Research conducted at a Vietnamese war site has demonstrated how acts of violence are translated into interpretive frameworks that balance historical authenticity with visitor expectations (Gillen, 2018). Likewise, studies of the Sewol-Ho ferry accident in South Korea examined how memorialization practices and the integration of digital technologies create new modes of engagement with tragedy (Kim & Yang, 2014). These cases reveal that dark tourism is not only about preserving sites but also about how narratives are constructed, mediated, and consumed in contemporary contexts.



Beyond Asia, dark tourism has also been scrutinized in contexts of political and natural disasters. A study in China on the Beichuan earthquake relics highlighted the relationship between motivation and experience, showing that tourists' prior expectations often shaped their post-visit reflections (Yan et al., 2016). Complementary research has examined intrapersonal constraints that prevent or discourage individuals from visiting dark tourism sites, such as fear, cultural taboos, or lack of awareness (Zheng et al., 2017). These findings indicate that dark tourism participation is not merely about interest or opportunity but about overcoming psychological and cultural barriers that vary across societies.

In Iran, research has drawn attention to both the potential and the limitations of dark tourism. A qualitative content analysis of Iranian dark tourism literature emphasized the cultural and historical specificity of sites within the country, while also noting the scarcity of systematic research on the subject (Mohammadi & Khodadad, 2019). Further studies have identified a range of barriers to dark tourism development in Iran, including infrastructural limitations, weak marketing strategies, and sociocultural sensitivities that complicate the promotion of such destinations (Massoudi Rad et al., 2018). These insights underscore the urgent need for more structured frameworks that can guide policymakers and tourism managers in addressing the unique challenges of developing dark tourism within the Iranian context.

The global expansion of dark tourism has inevitably raised philosophical and ethical questions. Scholars have debated whether dark tourism exploits human suffering for profit or serves a vital role in preserving collective memory. Some argue that visiting sites of tragedy allows individuals to reflect on mortality, ethics, and human fragility, making dark tourism a meaningful educational practice (Korstanje & George, 2015). Others caution that the commodification of suffering risks trivializing traumatic histories, leading to moral dilemmas about authenticity and respect (Bugrova, 2024). These debates highlight the dual nature of dark tourism: it can simultaneously empower remembrance and risk exploitation.

Another important strand of research concerns the role of local residents and their interaction with dark tourism. Residents' cognitive appraisals and emotional responses to tourism at local dark sites shape their support or resistance to such initiatives (Jordan & Prayag, 2022). Community engagement is therefore crucial in designing sustainable dark tourism strategies that respect local sensibilities while promoting educational and economic benefits.

Despite its global recognition, dark tourism remains a field that requires greater theoretical clarity and methodological rigor. Critical reviews of the literature emphasize that while progress has been made in understanding motivations, experiences, and management, there is still a need for integrative frameworks that bring together psychological, cultural, and managerial perspectives (Assylkhanova et al., 2024). This integrative approach is particularly relevant in contexts like Iran, where dark tourism intersects with sensitive historical, cultural, and political dynamics.

In sum, the literature on dark tourism illustrates both the promise and the challenges of this rapidly evolving field. Studies from diverse contexts—ranging from Nepal and Serbia to Vietnam, South Korea, and Iran—highlight the multifaceted nature of dark tourism as a practice that combines memory, identity, education, and commodification. While scholars agree that dark tourism can play an important role in cultural remembrance and heritage preservation, they also underscore the ethical dilemmas and practical challenges it entails. For countries like Iran, where historical events, cultural heritage, and sociopolitical sensitivities intersect, understanding the structural factors and developing strategies for managing dark tourism responsibly is essential.

This study therefore seeks to contribute to the growing body of knowledge by employing interpretive structural modeling and exploratory factor analysis to analyze the relationships among influencing factors and coping strategies for dark tourism in Iran.

## 2. Methods and Materials

This study employed a mixed-method design that combined qualitative exploration with quantitative validation in order to analyze the factors influencing dark tourism in Iran and to identify effective strategies for mitigating its negative consequences. In the qualitative phase, the participants consisted of experts, academics, and professionals in tourism, cultural heritage, and sociology who had direct or indirect experience with dark tourism phenomena. These individuals were selected through purposive sampling, and interviews were conducted until theoretical saturation was achieved. In the quantitative phase, the participants were inbound tourists who had visited dark tourism sites in Iran, such as war zones, disaster-stricken areas,



memorial museums, and cemeteries. Convenience sampling was used to recruit these tourists, and based on statistical requirements for exploratory factor analysis, a sample size of 384 respondents was determined. This two-stage participant selection allowed the study to capture both the expert perspective and the visitor experience, ensuring a comprehensive understanding of the subject matter.

In the qualitative stage, data were collected through semi-structured, in-depth interviews and focus groups with domain experts. These interviews were designed to uncover the indigenous dimensions of dark tourism in Iran and to account for its cultural and social particularities. The recorded discussions were transcribed and analyzed inductively to identify emerging codes, categories, and themes. In the quantitative stage, a closed-ended questionnaire was developed based on the results of the qualitative analysis. The instrument was structured on a five-point Likert scale and combined both standardized measures and researcher-designed items. The questionnaire was divided into two main sections: one addressing the underlying factors influencing dark tourism and another focusing on strategies for coping with its negative effects. Content validity of the questionnaire was confirmed by expert review, while reliability was established through Cronbach's alpha coefficients, all of which met acceptable thresholds. Additionally, measures of sampling adequacy such as the KMO index and Bartlett's test confirmed the suitability of the data for factor analysis.

Data analysis was conducted in two complementary stages. For the qualitative data, the transcripts of interviews and focus groups were subjected to inductive content analysis using MAXQDA software. Open, axial, and selective coding procedures were applied to organize the raw data into coherent themes and to construct the preliminary conceptual framework. For the quantitative data, exploratory factor analysis (EFA) was performed using SPSS to validate the structure of the factors and strategies identified in the qualitative phase. The results of EFA confirmed that the extracted factors had eigenvalues greater than one and together explained a substantial proportion of the total variance. Following this, the validated constructs were analyzed using Interpretive Structural Modeling (ISM) to stratify the factors and coping strategies into hierarchical levels. The ISM technique was particularly suited for identifying direct and indirect relationships among variables and for mapping the structural interdependencies. The final output was a stratified model that highlights the most fundamental and influential factors, as well as the most effective and responsive strategies for policy application. This integrative approach provided both theoretical depth and practical applicability for stakeholders in tourism management.

### 3. Findings and Results

Table 1 presents the main themes and their categorization into organizing themes (components) in order to identify the elements shaping the second overarching theme of the research, namely the influencing factors of dark tourism. As shown, the main themes were formed based on open codes identified and refined, and through the categorization of these themes, the organizing themes (components) were extracted.

**Table 1. Identified Indicators and Components for the Dimension of Influencing Factors on Dark Tourism**

Components	Indicators
Individual (Internal) Factors	Fascination with death
	Psychological characteristics of individuals
	Personality traits of individuals
	Interest in human catastrophes
	Innate human fear of death
	Level of historical knowledge of individuals
	Willingness to experience proximity to death in some individuals
Marketing and Information Factors	Curiosity in individuals
	Marketing actions of travel agencies
	Cultural activities and initiatives of government
	Political actions and activities of certain policymakers
Factors Related to the Nature of Dark Tourism	Advertising and dissemination of information in the media
	Superstitious beliefs
	Existing rumors about the site
	Attractiveness of dark tourism for some tourists
	Limited recognition of dark tourism
	Existence of potentials for developing dark tourism
	Diversity of dark tourism types



Level of welfare and comfort provided to tourists  
 Application of augmented reality technology  
 Application of virtual reality technology  
 Creation of new needs and interests among tourists

Page | 5 Table 2 presents the main themes and their categorization into organizing themes (components) in order to identify the elements shaping the third overarching theme of the research, namely strategies for addressing the negative aspects of dark tourism. As shown, the main themes were formed based on open codes identified and refined, and through the categorization of these themes, the organizing themes (components) were extracted.

**Table 2. Identified Indicators and Components for the Dimension of Coping Strategies against Dark Tourism**

Components	Indicators
Preventive Actions	Prohibition of entry into dangerous war zones
	Closure of sites with adverse psychological impacts
	Age categorization of dark tourism sites
Proactive Actions	Development of virtual presence instead of physical presence
	Issuance of necessary warnings regarding psychological consequences
	Prevention of rumor-spreading instead of factual dissemination
	Development of diverse tourism potentials tailored to each province
	Attention to local festivals
	Emphasis on historical and educational aspects

Table 3 further introduces the frequency of each main theme and the number of times it appeared across the documents.

**Table 3. Frequency and Number of Documents for Each Main Theme**

Main Themes	Frequency	Number of Documents
Proactive Actions \ Development of diverse tourism potentials tailored to each province	2	2
Proactive Actions \ Attention to local festivals	1	1
Proactive Actions \ Prevention of rumor-spreading instead of factual dissemination	1	1
Proactive Actions \ Emphasis on historical and educational aspects	3	2
Proactive Actions \ Issuance of necessary warnings regarding psychological consequences	1	1
Proactive Actions \ Development of virtual presence instead of physical presence	2	1
Preventive Actions \ Age categorization of dark tourism sites	1	1
Preventive Actions \ Closure of sites with adverse psychological impacts	1	1
Preventive Actions \ Prohibition of entry into dangerous war zones	1	1

Thus, based on the three tables above, the indicators and components shaping the three dimensions of the research—namely influencing factors, constitutive elements, and strategies for coping with the negative aspects of dark tourism—were identified. As stated, these three dimensions encompass 72 indicators with a total frequency of 179 codes. Table 4 presents the frequency of these 72 main themes or indicators and the number of their repetitions. The results of this table can assist in gaining an understanding of the most important indicators from the perspective of experts.

**Table 4. Extracted Questions for Factors after Exploratory Factor Analysis**

Factors	Extracted Questions
Locational Characteristics	Questions: 1-2-3-4-5-6-7-9-10
Event Characteristics	Questions: 11-12-13-14
Emotional Characteristics	Questions: 15-16-17-18-19-20-21-22-24
Cognitive Characteristics	Questions: 25-27-30-31-32
Other Characteristics	Questions: 34-35-36-37

Table 5 shows that the extracted components have eigenvalues greater than 1. Collectively, these components explain approximately 61% of the total variance of the questions.

**Table 5. Eigenvalues of Extracted Components**

Factors	Eigenvalue
Locational Characteristics	33.56
Event Characteristics	44.29
Emotional Characteristics	50.63
Cognitive Characteristics	55.97



Other Characteristics	60.99
-----------------------	-------

Since the KMO index is 0.777, which is greater than 0.6, conducting exploratory factor analysis is appropriate. Moreover, as the significance level of the chi-square statistic in Bartlett's test is smaller than 0.05, the null hypothesis—that the correlation matrix equals zero and there is no significant correlation—is rejected. Therefore, performing exploratory factor analysis is validated.

Table 6 presents the extracted factors along with the related questions. At this stage, all questions had sufficient correspondence with the factors and remained in the analysis. This table also demonstrates the correlation of each factor with the questionnaire questions.

**Table 6. Extracted Questions for Factors after Exploratory Factor Analysis**

Factors	Extracted Questions
Individual Factors	Questions: 1-2-3-4-5-6-7-8
Marketing and Information Factors	Questions: 9-10-11-12
Factors Related to Nature	Questions: 13-14-15-16-17-18
Developmental Actions	Questions: 19-20-21-22-23-24-25

Table 7 shows that the extracted components have eigenvalues greater than 1. Collectively, these components explain approximately 48% of the total variance of the questions.

**Table 7. Eigenvalues of Extracted Components**

Factors	Eigenvalue
Individual Factors	27.17
Marketing and Information Factors	34.75
Factors Related to Nature	41.77
Developmental Actions	47.30

Since the KMO index is 0.693, which is greater than 0.6, conducting exploratory factor analysis is appropriate. Moreover, as the significance level of the chi-square statistic in Bartlett's test is smaller than 0.05, the null hypothesis—that the correlation matrix equals zero and there is no significant correlation—is rejected. Therefore, performing exploratory factor analysis is validated.

Tables below present the results of the exploratory factor analysis. Table 8 displays the rotated factor matrix, while Table 9 provides the extracted factors along with the related questions. At this stage, all questions had sufficient correspondence with the factors and remained in the analysis. This table also demonstrates the correlation of each factor with the questionnaire questions.

**Table 8. Results of Exploratory Factor Analysis and Rotated Factor Matrix**

Questions	Factor 1	Factor 2
COP1	0.710	
COP2	0.469	
COP3	0.671	
COP4		0.615
COP5		0.679
COP6		0.449
COP7		0.569
COP8		0.462
COP9		0.566

**Table 9. Extracted Questions for Factors after Exploratory Factor Analysis**

Factors	Extracted Questions
Preventive Actions	Questions: 1-2-3
Proactive Actions	Questions: 4-5-6-7-8-9

Table 10 shows that the extracted components have eigenvalues greater than 1. Collectively, these components explain approximately 52% of the total variance of the questions.

**Table 10. Eigenvalues of Extracted Components**



Factors	Eigenvalue
Preventive Actions	34.12
Proactive Actions	51.22

In this section, quantitative data analysis is addressed. In this regard, the interpretive structural modeling (ISM) method and expert surveys were employed to stratify and identify the structural relationships among the 25 influencing factors of dark tourism in Iran, as well as the stratification and identification of relationships among the 9 strategies for coping with the negative aspects of this phenomenon. Based on the ISM method, the researcher first sought to identify the most important and influential factors and barriers over other factors and barriers, and simultaneously aimed to draw the structural relationships among these elements. In doing so, the study provides tourism decision-makers and stakeholders with a new understanding of how influencing factors and key coping strategies interact in relation to dark tourism.

These components emerged from the analyses conducted in the previous section, namely the interviews with experts regarding the causes and influencing factors of dark tourism in Iran, as well as the strategies and methods for coping with it. As mentioned earlier, the qualitative analysis indicated that 25 factors are capable of influencing the dark tourism phenomenon, and that 9 strategies can be applied to counter its negative aspects.

**Table 11. Indicators or Influencing Factors of Dark Tourism in Iran**

No.	Component	Symbol	No.	Component	Symbol
1	Fascination with death	C1	14	Existing rumors about the site	C14
2	Psychological characteristics of individuals	C2	15	Attractiveness of dark tourism for some tourists	C15
3	Personality traits of individuals	C3	16	Limited recognition of dark tourism	C16
4	Interest in human catastrophes	C4	17	Existence of development potentials for dark tourism	C17
5	Innate human fear of death	C5	18	Diversity of dark tourism types	C18
6	Level of historical knowledge of individuals	C6	19	Efforts toward capacity building	C19
7	Willingness to experience proximity to death in some individuals	C7	20	Preservation of authenticity and legitimacy	C20
8	Curiosity in individuals	C8	21	Degree of preservation and maintenance of sites	C21
9	Marketing actions of travel agencies	C9	22	Level of welfare and comfort for tourists	C22
10	Cultural activities and initiatives of government	C10	23	Use of augmented reality technology	C23
11	Political activities of certain policymakers	C11	24	Use of virtual reality technology	C24
12	Media advertising and dissemination of information	C12	25	Creation of new needs and interests among tourists	C25
13	Superstitious beliefs	C13			

**Table 12. Strategies for Coping with the Negative Aspects of Dark Tourism in Iran**

No.	Component	Symbol
1	Prohibition of entry into dangerous war zones	C1
2	Closure of sites with adverse psychological impacts	C2
3	Age categorization of dark tourism sites	C3
4	Development of virtual presence instead of physical presence	C4
5	Issuance of necessary warnings regarding psychological consequences	C5
6	Prevention of rumor-spreading instead of factual dissemination	C6
7	Development of diverse tourism potentials tailored to each province	C7
8	Attention to local festivals	C8
9	Emphasis on historical and educational aspects	C9

This step involved pairwise comparisons among the above factors to determine whether or not relationships existed between them. Experts were asked to express their views on the existence of one-way relationships, two-way relationships, or no relationship between the factors. For this purpose, experts were asked to indicate whether or not a relationship or effect existed. Opinions from 8 experts were collected. After individual responses were gathered, a joint session was held in which experts discussed their views to reach consensus, producing the final combined table shown below.

Once the relationships between two factors were established, the following notations were used to indicate the type of relationship between them:

- **V**: if factor A influences factor B, but B does not influence A;
- **A**: if factor A does not influence factor B, but B influences A;



- **X**: if both elements influence each other;
- **O**: if the two elements have no influence on each other.

In this step, based on the final reachability matrix, the 25 elements were stratified. The lower a factor is positioned, the greater its impact on other factors. In other words, in the stratification of the ISM method, the intensity of influence on other factors increases from top to bottom. Factors located at the highest level exert the least influence on other factors.

To stratify the factors, the following sets were defined:

- **Reachability set** for each factor: includes elements that factor A influences, in addition to factor A itself;
- **Antecedent set** for each factor: includes elements that influence factor A, in addition to factor A itself;
- **Intersection set** for each factor: the intersection between the two sets above.

The stratification process works such that in each round, factors with identical reachability and intersection sets are placed at one level and removed from subsequent rounds. The following rounds of stratification are then presented.

Based on the stratification provided, the final reachability matrix, and mapping relationships with priority given to elements in the same row or the immediately higher row—and finally, considering all relationships in the final reachability matrix, both direct and indirect—the interpretive structural model of the influencing factors of dark tourism is presented in Figure 1.

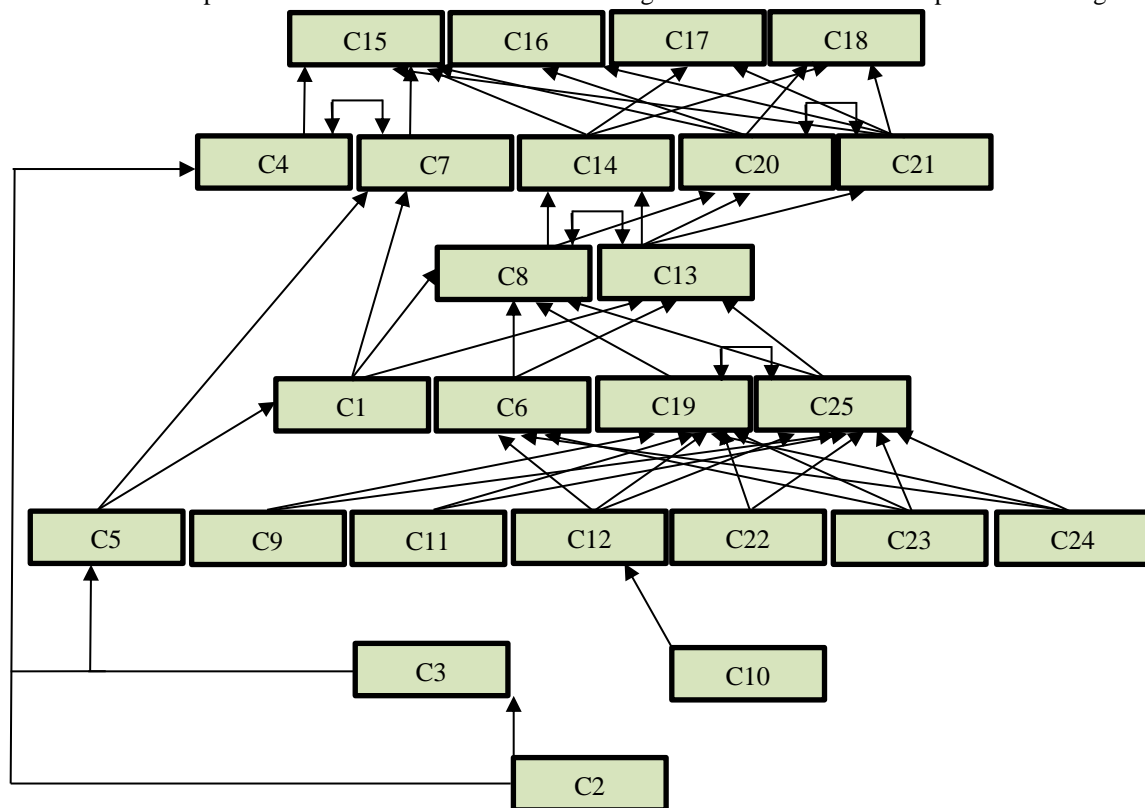

**Figure 1. Stratified Model of Influencing Factors of Dark Tourism in Iran and their Interrelationships**

As can be observed in the figure, the three elements C2, C3, and C10 have the greatest importance compared to the other factors, while the four elements C15, C16, C17, and C18 have the least importance relative to the other elements. The arrows in the figure are derived from the final reachability matrix, and the rule of drawing is such that if there is an indirect relationship between two elements in two levels with more than one difference, the direct relationship is not drawn. Based on this conclusion, the three elements or factors of the psychological characteristics of individuals (tourists), the personality traits of individuals (tourists), and the cultural activities of governments were identified as the most fundamental and influential factors in dark tourism compared to other factors. As is evident, two of the fundamental factors are individual factors, while one factor relates to governmental cultural activities in the field of tourism.

In addition, among the least important factors are the attractiveness of dark tourism for some tourists, the limited recognition of dark tourism, the existence of dark tourism development potentials, and the diversity of dark tourism types. In other words, these four factors were identified as the least influential relative to other influencing factors, and in a way, these four factors

are themselves consequences of other factors. Moreover, the factor of governmental cultural activities was identified as the most influential factor with both direct and indirect effects on other factors, while the attractiveness of dark tourism for some tourists was identified as the most affected factor by other factors, both directly and indirectly.

In continuation, the above steps are sequentially applied to the stratification of coping strategies with dark tourism in Iran. For this purpose, the structural self-interaction matrix, the initial and final reachability matrices, the stratification of factors, and finally, the stratified model are implemented.

Based on the results derived from the stratification of factors and the final reachability matrix related to coping strategies with dark tourism in Iran, the stratified model of these strategies and their interrelationships is presented in Figure 2.

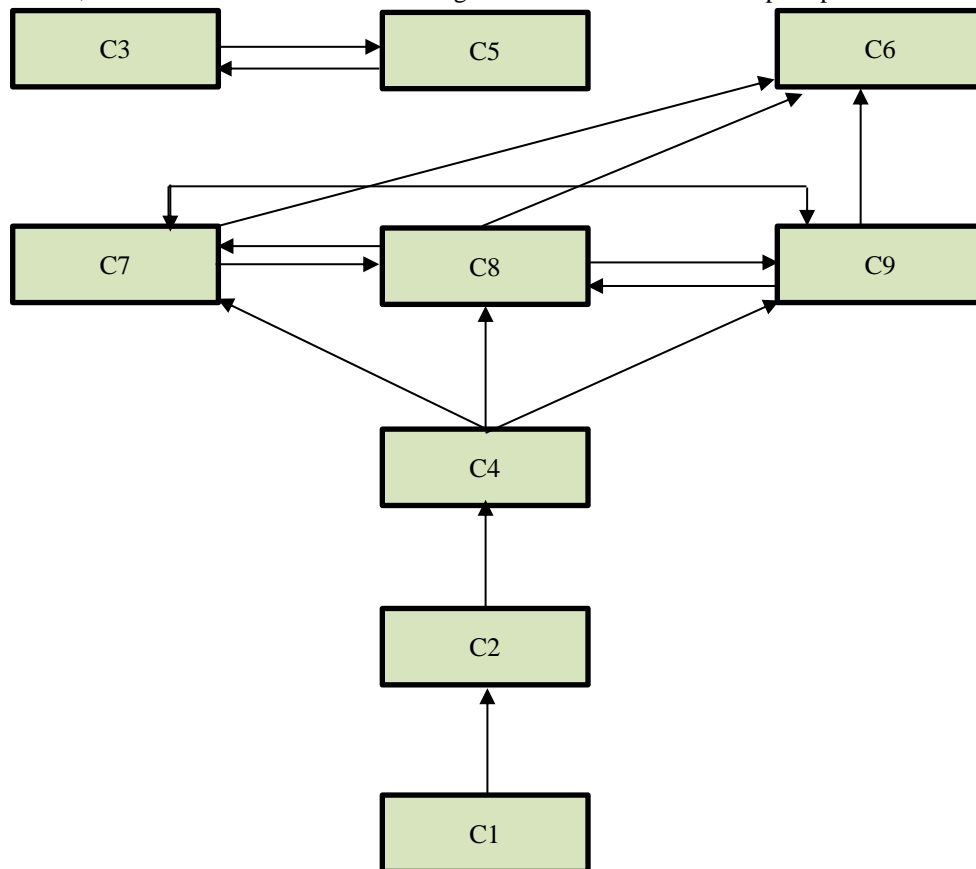

**Figure 2. Stratified Model of Coping Strategies with Dark Tourism in Iran and Their Interrelationships**

As can be seen in the figure, the single element C1 is the most important strategy compared to the other strategies, while the three strategies C6, C5, and C3 have the least importance compared to the others. The arrows in the figure are derived from the final reachability matrix, and the rule of drawing is such that if there is an indirect relationship between two elements in two levels with more than one difference, the direct relationship is not drawn. Based on this conclusion, the strategy of prohibiting entry into dark tourism sites—and specifically, prohibiting entry into historical war sites—was identified as the most fundamental and influential strategy compared to the other strategies for coping with dark tourism. As is evident, this strategy, as a preventive measure, seeks to prohibit visits to dark tourism sites (a substantial portion of which in the country are related to war sites).

Furthermore, among the least important and least influential strategies are the age categorization of dark tourism sites, the issuance of necessary warnings regarding the psychological consequences of visiting such places, and the prevention of rumor-spreading instead of the dissemination of facts. In other words, these three strategies were identified as the least influential relative to the others and, in a way, are themselves consequences of other strategies. Additionally, based on the results derived from the final reachability matrix, the strategy of developing virtual presence instead of physical presence was identified as the most influential strategy over other strategies, while the strategy of focusing on historical and educational aspects was identified as the most affected strategy by other strategies.

In continuation, the above steps are sequentially applied to the stratification of the constitutive elements of the dark tourism phenomenon in Iran. For this purpose, the structural self-interaction matrix, the initial and final reachability matrices, the stratification of factors, and finally, the stratified model are implemented. In this section as well, based on the opinions of 8 experts and the aggregation of their views, the final structural self-interaction matrix is obtained. First, in Table 13, the final elements derived from the exploratory factor analysis are introduced.

**Table 13. Constitutive Elements of the Dark Tourism Phenomenon**

No.	Component	Symbol	No.	Component	Symbol
1	Sites with high suicide rates	C1	17	Experience of fear and terror	C17
2	Religious sites and sacrificial grounds	C2	18	Creating a sense of grief in the visitor	C18
3	Cemeteries	C3	19	Sympathy with victims	C19
4	Detention and torture sites of prisoners and slaves	C4	20	Experiencing the feeling of death	C20
5	Impoverished and disaster-stricken areas	C5	21	Experiencing the sense of violence occurred	C21
6	Famous prisons and detention centers	C6	22	Creating anxiety in the tourist	C22
7	Sites of mysterious incidents	C7	23	Understanding atrocities committed in the past	C23
8	War conflict zones	C8	24	Creating deep reflection on humanity in individuals	C24
9	Sites of natural disasters	C9	25	Contemplating death	C25
10	Occurrence of a human tragedy	C10	26	Visiting with the aim of recognizing events	C26
11	Events and evidence of death	C11	27	Visiting with the aim of remembrance	C27
12	Events and evidence of cruelty	C12	28	Visiting with the aim of education and learning	C28
13	Events involving human suffering	C13	29	Depicting the sorrow and grief of inhabitants	C29
14	High intensity of individual emotional responses	C14	30	Existence of pleasure for some tourists	C30
15	Simultaneous engagement of vision and emotions with bitterness	C15	31	Visiting with the aim of curiosity	C31
16	Engaging imagination in individuals	C16	32	Commercialization of dark historical events	C32

Now, based on the defined stratification and the initial reachability matrix (without considering transitive relationships), the stratified model of the constitutive elements of the dark tourism phenomenon in Iran is presented as follows:



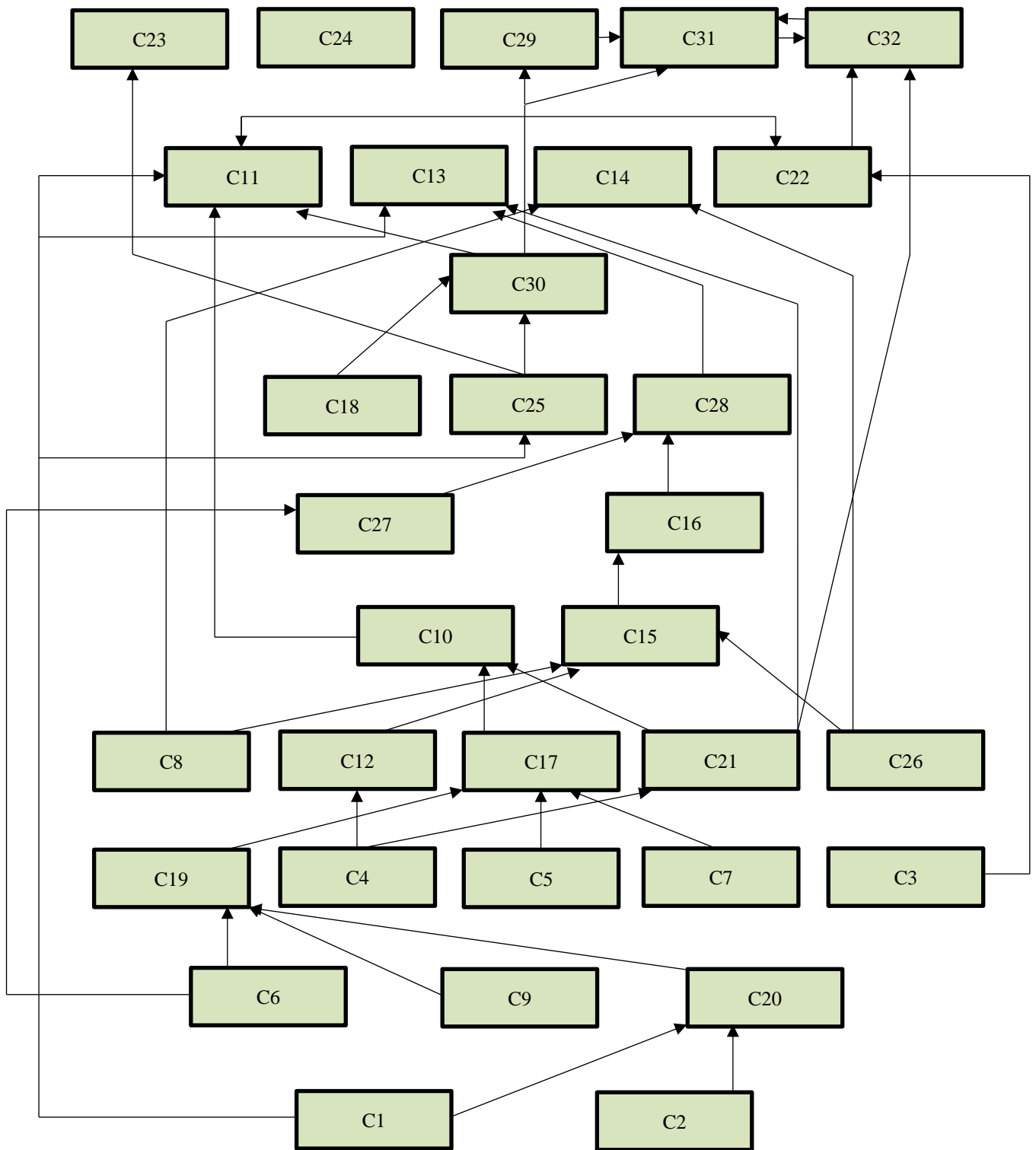

**Figure 3. Stratified Model of the Constitutive Elements of Dark Tourism in Iran and Their Interrelationships**

As can be observed in the figure, the elements C1, C2, C6, C9, and C20 have the greatest importance compared to the other factors. The arrows in the figure are derived from the initial reachability matrix, and the rule of drawing is such that if there is an indirect relationship between two elements in two levels with more than one difference, the direct relationship is not drawn. Based on this conclusion, the elements associated with the locational characteristics of a dark tourism site were identified as the most important and fundamental constitutive elements of the dark tourism phenomenon.

From this conclusion, it can be inferred that essentially, a dark tourism site is defined by its locational characteristics, such as the place of wars, human tragedies, natural disasters, or human suffering. It is natural that these characteristics, as fundamental attributes, themselves act as influencing factors over other features.

#### 4. Discussion and Conclusion

The findings of this study revealed that dark tourism in Iran is influenced primarily by the psychological and personality characteristics of tourists, alongside the cultural measures implemented by the government. In contrast, factors such as the limited attractiveness of dark tourism, low public awareness, and untapped development potentials were found to be the least influential. Furthermore, strategies for mitigating the negative aspects of dark tourism pointed toward prohibiting entry into dangerous war sites as the most fundamental solution, while focusing on historical and educational dimensions emerged as the most responsive strategy. These outcomes provide both theoretical and practical insights into the dynamics of dark tourism in the Iranian context and resonate with, as well as diverge from, patterns observed in international scholarship.

A central finding concerns the critical role of tourists' psychological and personality traits in shaping their engagement with dark tourism sites. The appeal of dark destinations often emerges from deep psychological needs, such as fascination with mortality, curiosity about human suffering, or a desire for reflective experiences. Previous research has consistently highlighted that emotional and cognitive factors are central in shaping motivations and experiences at dark sites (Yan et al., 2016). Studies in China, for instance, demonstrated that prior motivations influence how tourists process their experiences when visiting earthquake relics, underscoring the interplay between internal drives and external contexts (Yan et al., 2016). Similarly, research on intrapersonal constraints emphasizes that psychological barriers—such as fear or cultural taboos—can shape participation, suggesting that personality characteristics not only motivate but also delimit dark tourism engagement (Zheng et al., 2017). Our findings are therefore aligned with this body of literature, demonstrating that psychological dispositions are not peripheral but foundational in explaining dark tourism participation.

Equally significant is the identification of government cultural measures as a core determinant in shaping dark tourism in Iran. This highlights the importance of top-down initiatives in framing narratives, ensuring ethical interpretation, and designing educational frameworks around sites of tragedy. Previous research in heritage tourism has already stressed the dissonance created when commercial imperatives clash with commemorative intentions (Hartmann, 2014). Governments, by instituting cultural and educational programs, play a decisive role in mitigating these tensions. The Iranian case reflects a broader global pattern where institutional and political interventions significantly shape how dark tourism evolves. For instance, in South Korea, memorialization of the Sewol-Ho ferry accident was deeply intertwined with cultural policy and media practices, showing how state involvement mediates the balance between education, mourning, and commodification (Kim & Yang, 2014). Similarly, studies from Serbia emphasize the role of national memory politics in structuring memorial parks and shaping collective identity (Miletić et al., 2023). By identifying cultural measures as fundamental, this study corroborates the argument that dark tourism cannot be left solely to market mechanisms; it requires sustained governance and ethical oversight.

On the other hand, the finding that limited attractiveness and low public awareness are the least influential factors suggests that structural barriers, rather than simple marketing gaps, may inhibit the development of dark tourism in Iran. This result may initially appear surprising, as previous studies in Iran have identified infrastructural weaknesses and inadequate promotional strategies as major obstacles (Massoudi Rad et al., 2018; Mohammadi & Khodadad, 2019). However, the current study's results suggest that while such issues exist, they are less foundational compared to psychological and institutional dimensions. International evidence supports this interpretation. Research in Vietnam showed that the operationalization of violence and tragedy at dark sites required careful cultural framing, not merely marketing techniques (Gillen, 2018). Similarly, studies on visitor motivations at the War Memorial of Korea and China confirmed that branding and awareness are secondary to the deeper affective and cognitive connections that tourists establish with such sites (Lee & Newpaney, 2017). Thus, although awareness campaigns are useful, their impact is constrained unless combined with strategies addressing deeper psychological and cultural foundations.

The strategies identified in this study also provide fertile ground for comparison with global scholarship. Prohibiting access to dangerous war zones as the most influential strategy underscores the necessity of protecting visitors from physical and



psychological harm. While dark tourism sites thrive on their association with trauma and risk, excessive exposure to danger undermines both safety and ethical standards. Similar concerns have been raised internationally regarding the balance between authenticity and safety. For example, research on seismic memorial sites in Nepal highlighted the need for careful management to avoid re-traumatizing communities or exposing tourists to hazards (Kunwar et al., 2019). Likewise, studies in South Africa noted that motivations for visiting sites of atrocity are often rooted in respect for victims, and unregulated access risks trivializing or sensationalizing the experience (Nhlabathi & Maharaj, 2020). Iran's emphasis on restricting dangerous access is therefore consistent with international best practices in ensuring that dark tourism serves commemorative rather than exploitative purposes.

The identification of historical and educational emphasis as the most responsive strategy provides further evidence of the centrality of edutainment and pedagogical approaches in shaping meaningful dark tourism experiences. Previous studies have shown that visitors respond positively when interpretive frameworks combine historical depth with engaging storytelling, creating a balance between emotional engagement and learning (Wyatt et al., 2020). Research on embodied experiences also underlines that tourists' sensory and affective responses are enhanced when narratives encourage reflection and understanding (Sun & Lv, 2020). In the Iranian context, prioritizing historical and educational aspects may counteract concerns about commercialization, aligning with global findings that education transforms dark tourism into a socially constructive practice (Jordan & Prayag, 2022).

When examining international perspectives, the Iranian case fits within the broader trajectory of dark tourism scholarship, which emphasizes both universal and context-specific dimensions. A critical review of global studies reveals that while motivations, management, and ethical debates are common across countries, each context introduces unique historical and cultural considerations (Assylkhanova et al., 2024). For example, in Europe, issues of heritage dissonance dominate debates, while in Asia, questions of authenticity and modernization are central (Light, 2017). Iran, with its complex historical narratives and cultural sensitivities, adds another layer to this global discourse. By confirming the foundational role of psychological and governmental factors, this study advances theoretical understanding while providing practical insights for managing dark tourism in culturally complex contexts.

Furthermore, the Iranian findings resonate with philosophical debates about whether dark tourism is inherently exploitative or educative. Some scholars argue that the commodification of tragedy risks trivializing human suffering, while others see dark tourism as an opportunity to preserve memory and promote moral reflection (Bugrova, 2024; Korstanje & George, 2015). Our results demonstrate that the trajectory of dark tourism in Iran is highly contingent on how government agencies frame and regulate experiences. If left unchecked, market pressures may push sites toward sensationalism, but when guided by cultural policies, dark tourism can serve educational and commemorative functions. This dual potential reflects the paradox at the heart of dark tourism: its ability to be both problematic and productive, depending on management strategies.

Additionally, this study contributes to the understanding of intrapersonal and cultural barriers. The finding that development potentials are perceived as less impactful suggests that psychological and cultural constraints weigh more heavily than infrastructural opportunities. Research in China demonstrated that individuals who avoided dark sites often cited personal discomfort and cultural taboos as reasons, even when accessibility and infrastructure were adequate (Zheng et al., 2017). Similarly, studies in Korea and China highlighted differences in how cultural contexts shape the symbolic meanings of war memorials (Lee & Newpaney, 2017). This supports the interpretation that dark tourism development is not primarily limited by physical resources but by deeper cultural and psychological dynamics that must be addressed through sensitive management and policy-making.

Finally, the study reinforces the view that dark tourism is not merely a passive form of consumption but an active process of meaning-making. Scholars have argued that visiting sites of tragedy enables individuals to reflect on existential questions, connect with collective memory, and negotiate their own identities (Hartmann, 2014; Light, 2017). Our findings support this interpretation by demonstrating that tourists' internal dispositions and the cultural frameworks established by governments are the most influential determinants of engagement. The Iranian context thus contributes to the ongoing global discussion about how dark tourism can move beyond commodification to become a meaningful cultural and educational practice.



Despite its contributions, this study has certain limitations that should be acknowledged. The reliance on purposive and convenience sampling may limit the generalizability of the results, particularly in the quantitative phase that involved inbound tourists. While the sample size was statistically adequate, it may not fully capture the diversity of perspectives among different demographic groups or among international visitors unfamiliar with Iranian cultural contexts. Additionally, the study relied primarily on self-reported data, which can be influenced by social desirability bias or incomplete recollection of experiences. Another limitation lies in the cross-sectional design, which captures attitudes and experiences at a single point in time rather than observing their evolution over longer periods. Finally, the sensitive nature of dark tourism in Iran, with its political and cultural dimensions, may have constrained participants' willingness to fully articulate critical perspectives.

Future research should aim to expand both the scope and depth of inquiry into dark tourism in Iran and comparable contexts. Longitudinal studies could provide insights into how attitudes and experiences evolve over time, particularly as sites develop or as government policies change. Comparative research between Iranian dark tourism sites and those in other countries could help identify universal versus context-specific dynamics, enriching theoretical frameworks. Future studies should also adopt mixed-method approaches that integrate quantitative surveys with ethnographic observations, enabling deeper understanding of embodied and affective dimensions of dark tourism. Finally, further investigation into residents' perspectives and community-level impacts could shed light on how local populations negotiate the commodification of their histories, thereby providing a more holistic understanding of the social implications of dark tourism.

For policymakers and practitioners, several practical implications emerge. First, strategies should prioritize ethical frameworks that balance commemoration with sustainability, ensuring that sites respect victims while providing educational value. Second, safety regulations must be strictly enforced, particularly concerning access to dangerous war zones, in order to protect both visitors and host communities. Third, interpretation strategies should emphasize historical accuracy and educational content, supported by interactive and engaging storytelling that resonates with diverse audiences. Fourth, policymakers should invest in training programs for guides and staff to ensure culturally sensitive and ethically responsible interactions. Finally, marketing efforts should be carefully framed to avoid sensationalism, instead positioning dark tourism as a vehicle for learning, reflection, and cultural preservation.

## Ethical Considerations

All procedures performed in this study were under the ethical standards.

## Acknowledgments

Authors thank all who helped us through this study.

## Conflict of Interest

The authors report no conflict of interest.

## Funding/Financial Support

According to the authors, this article has no financial support.

## References

- Assylkhanova, A., Nagy, G., Morar, C., Teleubay, Z. B., & Boros, L. (2024). A Critical Review of Dark Tourism Studies. *Hungarian Geographical Bulletin*, 73(4), 413-435. <https://doi.org/10.15201/hungeobull.73.4.5>
- Bugrova, E. D. (2024). Issues Of Studying Dark Tourism as A Factor in Preserving Cultural and Historical Memory. *Izvestia Ural Federal University Journal Series I Issues in Education Science and Culture*, 30(2), 133-141. <https://doi.org/10.15826/izv1.2024.30.2.033>
- Gillen, J. (2018). It Begins With the Bombs: Operationalizing Violence at a Vietnamese Dark Tourism Site. *cultural geographies*, 25(4), 519-536. <https://doi.org/10.1177/1474474018762810>
- Hartmann, R. (2014). Dark tourism, thanatourism and dissonance in heritage tourism management: New directions in contemporary tourism research. *Journal of Heritage Tourism*, 9(2), 166-182. <https://doi.org/10.1080/1743873X.2013.807266>
- Jordan, E. J., & Prayag, G. (2022). Residents' Cognitive Appraisals, Emotions, and Coping Strategies at Local Dark Tourism Sites. *Journal of Travel Research*, 61(4), 887-902. <https://doi.org/10.1177/00472875211004761>



- Khalid, U. A., Sham, I. F. H., Dzulkarnain, N. S., & Lonsiong, R. S. (2023). Motivational Factors of Sabahan Youth for Visiting Dark Tourism Sites. *International Journal of Academic Research in Business and Social Sciences*, 13(5). <https://doi.org/10.6007/ijarbs/v13-i5/17024>
- Kim, H.-S., & Yang, J.-H. (2014). The Application Methods of Dark Tourism Contents in SEWOL-HO Ferry Accident. *The Journal of the Korea Contents Association*, 14(9), 176-187. <https://doi.org/10.5392/jkca.2014.14.09.176>
- Korstanje, M., & George, B. (2015). Dark tourism: Revisiting some philosophical issues. *e-Review of Tourism Research*, 12(1/2), 127-136.
- Kunwar, R. R., Aryal, D. R., & Karki, N. (2019). Dark Tourism: A Preliminary Study of Barpak and Langtang as Seismic Memorial Sites of Nepal. *Journal of Tourism and Hospitality Education*, 9, 88-136. <https://doi.org/10.3126/jthe.v9i0.23683>
- Lee, S. K., & Newpaney, R. (2017). A Study on the Difference of the Visitors' Motivation and Brand Equity of Dark Tourism Visitor: Focused on the War Memorial of Korea and China. <https://doi.org/10.20472/iac.2017.33.040>
- Light, D. (2017). Progress in dark tourism and thanatourism research: An uneasy relationship with heritage tourism. *Tourism Management*, 61, 275-301. <https://doi.org/https://doi.org/10.1016/j.tourman.2017.01.011>
- Massoudi Rad, M., Ahmadi, A., & Rezaei, M. (2018). Analysis of Barriers to Dark Tourism Development in Iran. *urban tourism*, 5(2), 35-51. [https://jut.ut.ac.ir/article\\_66785.html](https://jut.ut.ac.ir/article_66785.html)
- Miletić, R., Pantović, D., & Veliveronena, L. (2023). Dark Tourism in Serbia: Case Study of the Kragujevački Oktobar Memorial Park. *Menadžment U Hotelijerstvu I Turizmu*, 11(1), 127-144. <https://doi.org/10.5937/menhottur2301127m>
- Mohammadi, S., & Khodadad, M. (2019). *Qualitative Content Analysis of Dark Tourism in Iran (Based on Articles on Dark Tourism)* The 14th Congress of the Iranian Geographical Association, Tehran. <https://en.civilica.com/doc/876581/>
- Nhlabathi, S. S., & Maharaj, B. (2020). The dark tourism discipline: a creative brand in a competitive academic environment? *Current Issues in Tourism*, 23(19), 2428-2439. <https://doi.org/https://doi.org/10.1080/13683500.2019.1636770>
- Sun, J., & Lv, X. (2020). Feeling dark, seeing dark: Mind-body in dark tourism. *Annals of Tourism Research*, 86, 103087. <https://doi.org/https://doi.org/10.1016/j.annals.2020.103087>
- Wyatt, B., Leask, A., & Barron, P. (2020). Designing dark tourism experiences: an exploration of edutainment interpretation at lighter dark visitor attractions. *Journal of Heritage Tourism*, 1-17. <https://doi.org/https://doi.org/10.1080/1743873X.2020.1858087>
- Yan, B. J., Zhang, J., Zhang, H. L., Lu, S. J., & Guo, Y. R. (2016). Investigating the motivation-experience relationship in a dark tourism space: A case study of the Beichuan earthquake relics, China. *Tourism Management*, 53, 108-121. <https://doi.org/https://doi.org/10.1016/j.tourman.2015.09.014>
- Zheng, C., Zhang, J., Zhang, H., & Qian, L. (2017). Exploring sub-dimensions of intrapersonal constraints to visiting "dark tourism" sites: A comparison of participants and non-participants. *Asia Pacific Journal of Tourism Research*, 22(1), 21-33. <https://doi.org/10.1080/10941665.2016.1175489>

